



INFORMATION FOR FIRST AND SECOND RESPONDERS

EMERGENCY RESPONSE GUIDE FOR VEHICLE



smart #3

BATTERY ELECTRIC VEHICLE





CONTENTS

0. Rescue sheet(s)	Page 1
1. Identification / recognition	Page 2
2. Immobilisation / stabilisation / lifting	Page 4
3. Disable direct hazards / safety regulations	Page 6
4. Access to the occupants	Page 11
5. Stored energy / liquids / gases / solids	Page 16
6. In case of fire	Page 17
7. In case of submersion	Page 18
8. Towing / transportation / storage	Page 19
9. Important additional information	Page 21
10. Explanation of pictograms used	Page 22

0. Rescue sheet(s)



smart #3
5-door model,
as of 2023

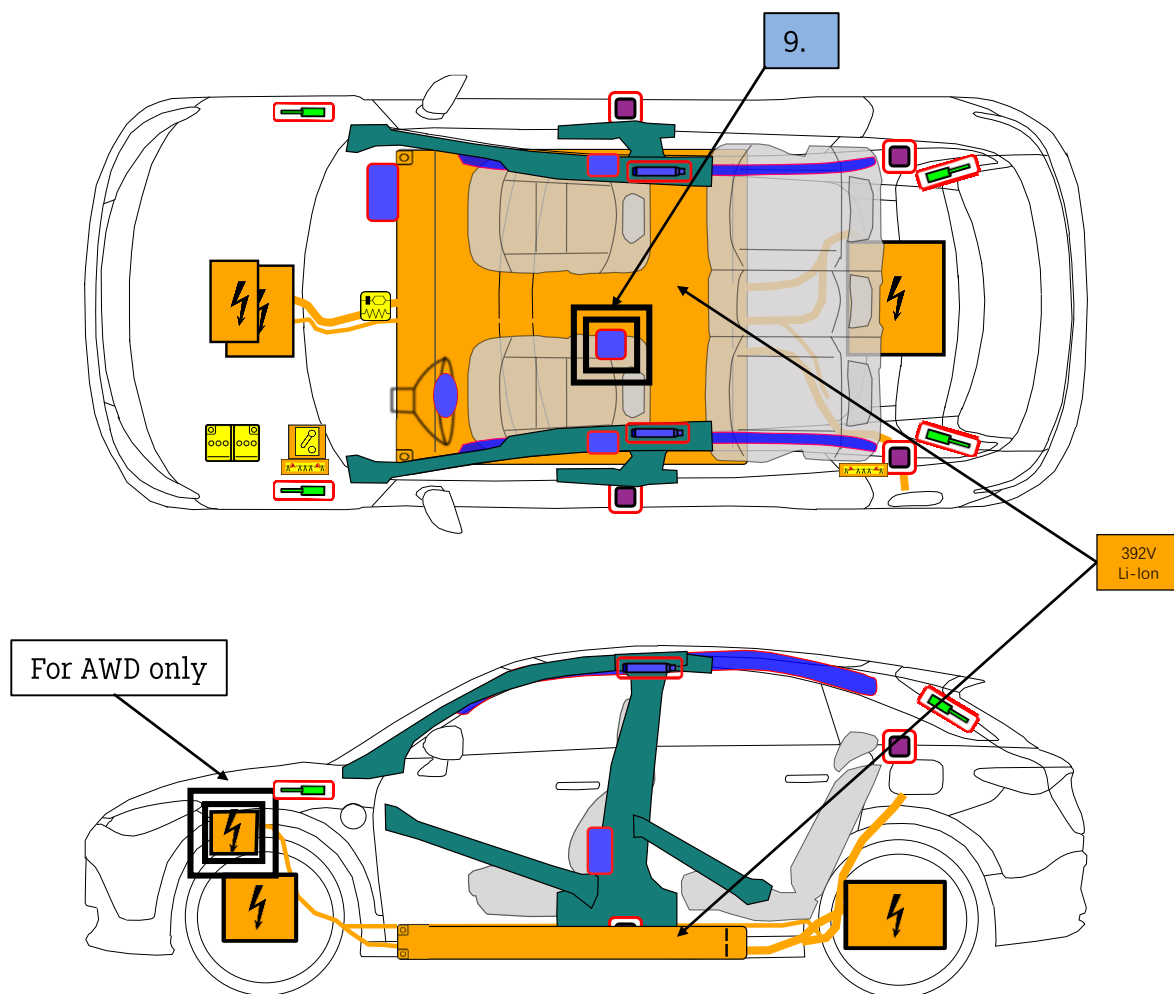

	Airbag		Stored gas inflator		Seat belt pretensioner		SRS control unit		Cable cut
	Battery pack, high-voltage		Gas strut / Preloaded spring		High strength zone		Battery low voltage		
	Low voltage device that disconnects high voltage		High voltage power cable		Zone requiring special attention		High voltage component		



1. Identification / recognition



WARNING LACK OF ENGINE NOISE DOES NOT MEAN VEHICLE IS OFF. SILENT MOVEMENT OR INSTANT RESTART CAPABILITY EXISTS UNTIL VEHICLE IS FULLY SHUT DOWN. WEAR APPROPRIATE PERSONAL PROTECTIVE EQUIPMENT (PPE).

Badge and Door Handles

smart #3 is an electric vehicle. It can be identified by its badges on the tailgate.

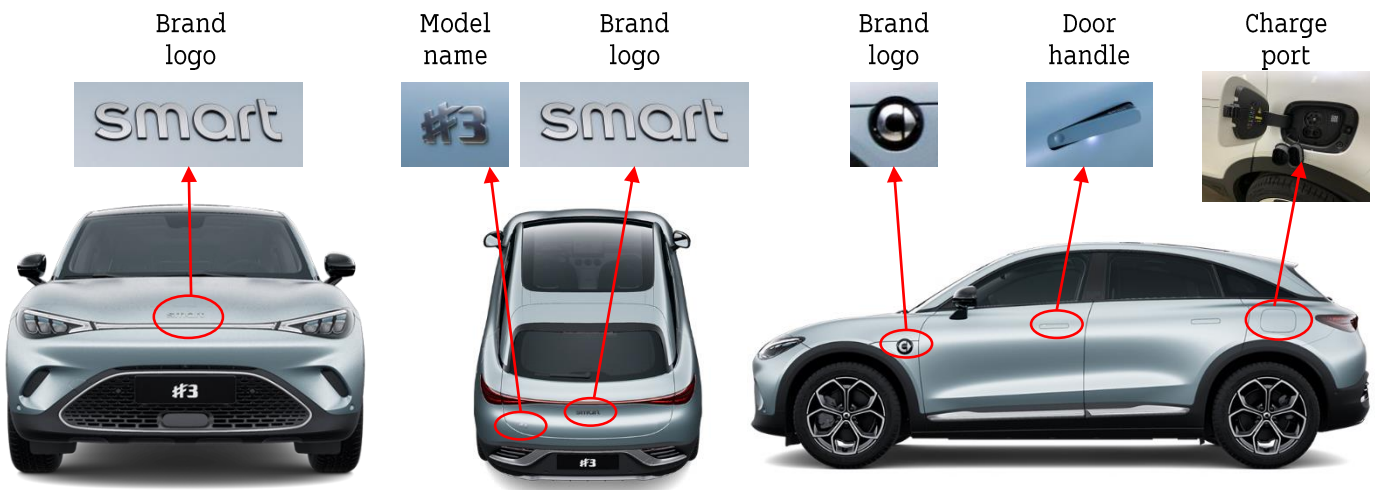

Vehicle Identification Number (VIN)

smart #3 can be identified by its VIN which is located at the stamped plate on the top of the dashboard at the driver's side of the windshield ①. #3 is identified with a "C" in the 4th alphanumeric position.

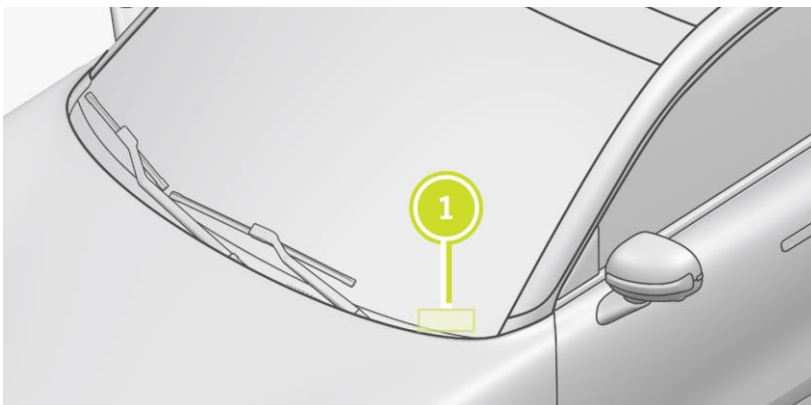



The VIN can also be found on the passenger's side B-pillar ②, and the carpet below the passenger seat ③.

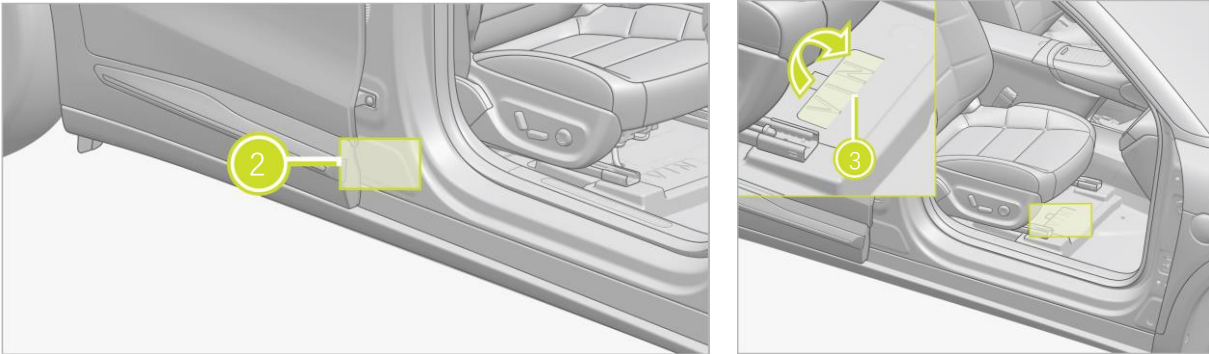

Keys

smart #3 supports 2 types of keys.

1. Key fob

The key fob is styled round. It allows you to press buttons to unlock, lock the side doors and tailgate, and drive #3. Use the key buttons as shown below.



- ① Press to unlock - steering indicator flashes.
- ② Briefly press to unlock/lock the tailgate; Long press to open/close the tailgate.
- ③ Press to lock - steering indicator flashes.

2. Digital key-BLE

Personal smartphone can be set up to communicate with #3 through Bluetooth. If a smartphone is already paired to the vehicle, open the smart mobile app on the smartphone and then unlock or lock #3.



2. Immobilisation / stabilisation / lifting

IMMOBILISATION

1. Clock wheels

After the vehicle is shut down, the vehicle should be stabilized by using tire chocks.



WARNING Be careful! Do not damage the high-voltage battery pack when stabilizing the vehicle.

2. Put vehicle into Park position

Block wheels by depressing the brake pedal ① and press switch P at the selector level to select the P (park) position ②.

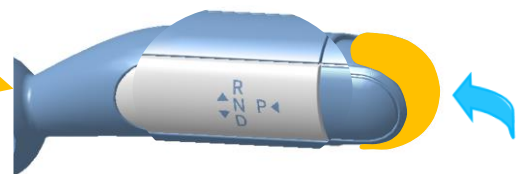
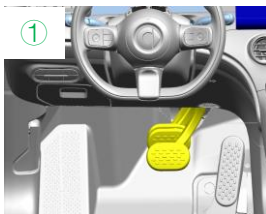

Whenever the #3 is in Park, the brake is activated automatically, and the cluster shows the active gear as P (Park), outlined in red, see picture below.

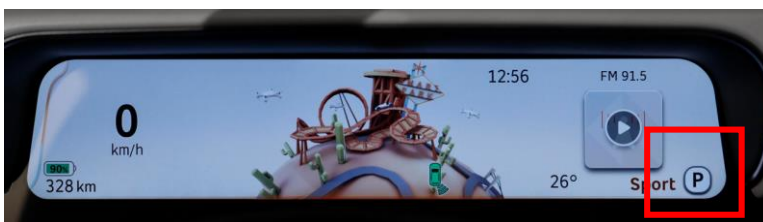



STABILISATION - LIFTING POINTS

The high voltage battery is located under the floor.

A large section of the undercarriage houses the high voltage battery. When lifting or stabilizing the #3, only use the designated lift areas, as shown in green.



WARNING Be careful to not damage the high-voltage battery pack while stabilizing / lifting the vehicle.



WARNING The vehicle should be lifted or manipulated only if first responders are familiar with the vehicle's lifting points. If you need to contact the high-voltage battery or other high voltage components, always wear appropriate PPE and cut off the high voltage system.



WARNING Do not use the high voltage battery to lift or stabilize the vehicle.

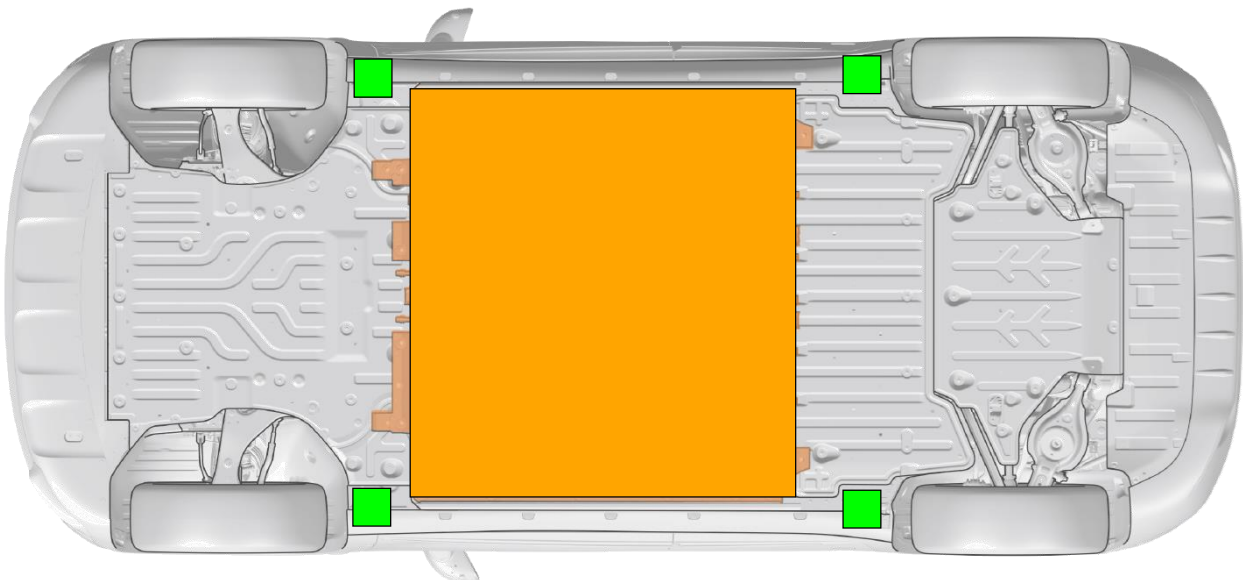

 Appropriate lifting points;

 High voltage battery;

3. Disable direct hazards / safety regulations

ACCESS

- 1, Open the hood (see chapter 4: Access to the Occupant)
- 2, Remove the 12V battery cover board.

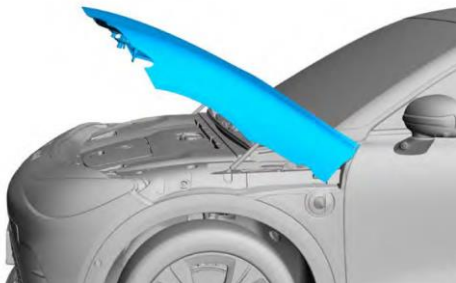

MAIN DISABLE METHOD

- 1, Pull out the red tab outwards completely to disconnect the high voltage;
- 2, Disconnect the 12V battery. Please ensure that the negative cable connector of the 12V battery does not touch the vehicle body metal parts.



1, Pull out red tab 2, pull out black connector

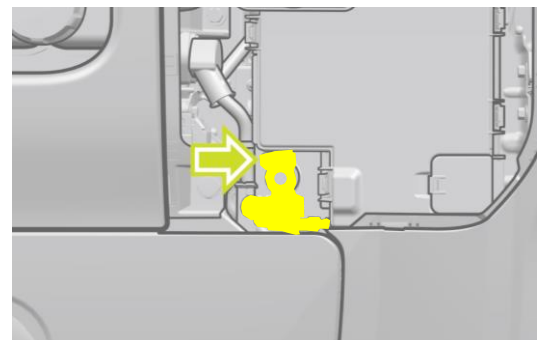

WARNING Wait at least 5 minutes for the high-voltage system capacitance to fully discharge before performing rescue work.

In an emergency, rescue work can be carried out directly after disconnecting the high-voltage system, but must wear appropriate PPE, otherwise may cause death or serious injury.

Alternative method 1: Cut the removable cable in the engine compartment.

- 1, Cut and remove the wiring harness with rescue signs;
- 2, Disconnect the 12V battery.

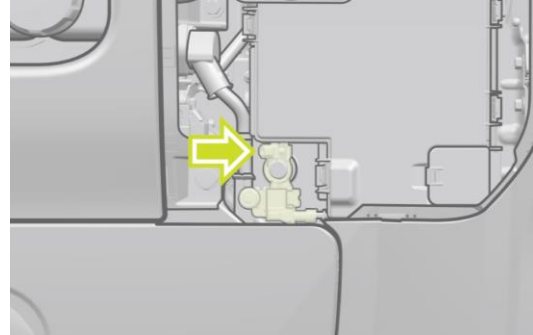
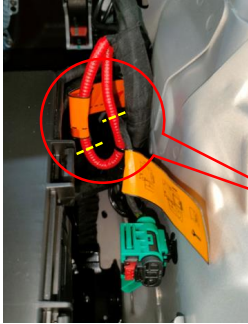

Alternative method 2: Cut the removable cable in the passenger compartment.

- 1, Break the left side triangular window;
- 2, Remove the interior panel;
- 3, Cut the removable cable; follow the instructions on the label;
- 4, Disconnect the 12V battery.

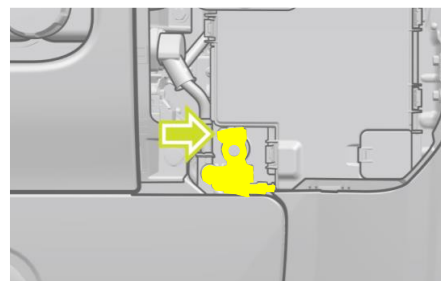
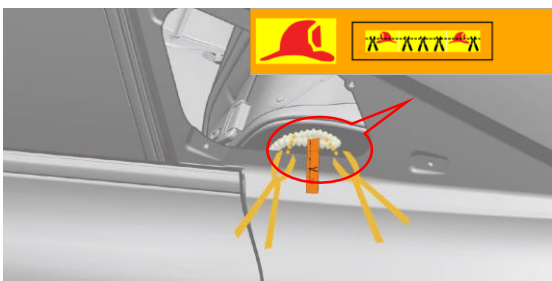
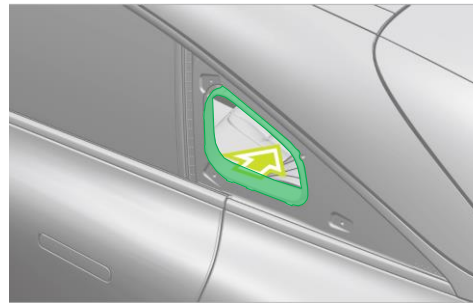
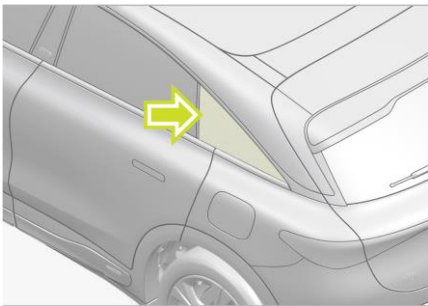

Safety regulations:



Always assume the vehicle is powered, even if it is silent!
 Make sure that the vehicle is immobilized and the propulsion system is deactivated;
 Never touch, cut, or open any orange high voltage power cable or high voltage component;
 In case of a collision with airbag deployment and/or seat belt pretensioner activation, the propulsion system will be disabled.



Cable Cut

The First Responder Loop is located on the left-side of the vehicle for both left-hand drive vehicles and right-hand drive vehicles.

When the vehicle has been in an accident and the First Responder Loop is cut off, always consider the high voltage package as live because the package will still have stored energy within it, and it is not known whether the other high-voltage components have been damaged. Treat orange cable and battery pack as if they had a high voltage inside. Do not cut the orange high-voltage cable or cut the battery package.

When a vehicle encounters an accident, the energy inside can't be instantly released. There is stored energy in battery cells. Care must be taken not to damage the package when vehicle extrication operation occurs.

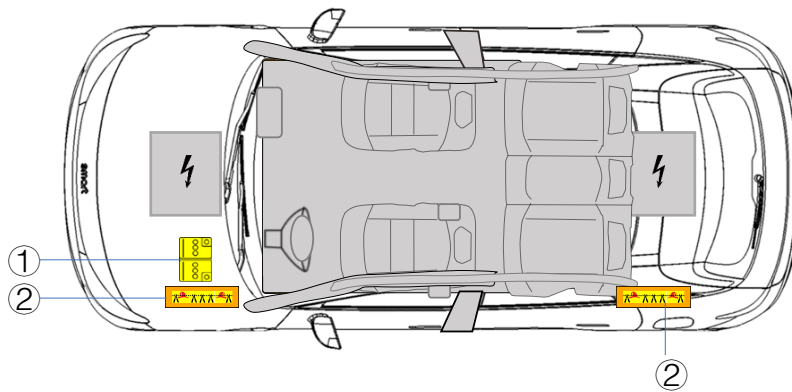

- ① 12V Battery
- ② First Responder Cut Loop

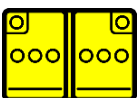

Battery low-voltage

When the vehicle's hood is opened, the 12V battery is accessible after removing the cover board. When necessary, remove the 12V battery negative electrode retaining nut and remove the 12V battery negative electrode cable.

Please ensure that the negative cable connector of the 12V battery does not touch the vehicle body metal parts.



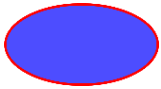

Airbags

Airbags are located in the approximate areas shown below. Airbag warning information is printed on the sun visors.

When the airbags have been deployed by the Supplemental Restraint System (SRS), the vehicle's high voltage system will be simultaneously cut off.

When the vehicle has been in an accident and the First Responder Loop is cut off, always consider the high voltage package as live because the package will still have stored energy within it, and it is not known whether the other high-voltage components have been damaged. Treat orange cable and battery pack as if they had a high voltage inside. Do not cut the orange high-voltage cable or cut the battery package.

NOTE: On Right Hand Drive vehicles, the components are mirrored.

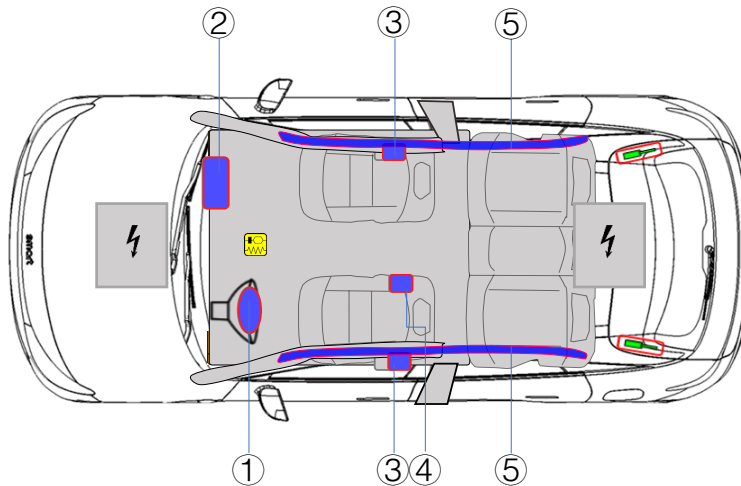

- ① Driver airbag
- ② Passenger airbag
- ③ Side airbags
- ④ Centre airbag (Far-side airbag)
- ⑤ Curtain airbags



Seat belt pretensioner

The seat belt pre-tensioners, outlined in red, are located at the bottom of the B-pillars and outboard of the 2nd row seats.

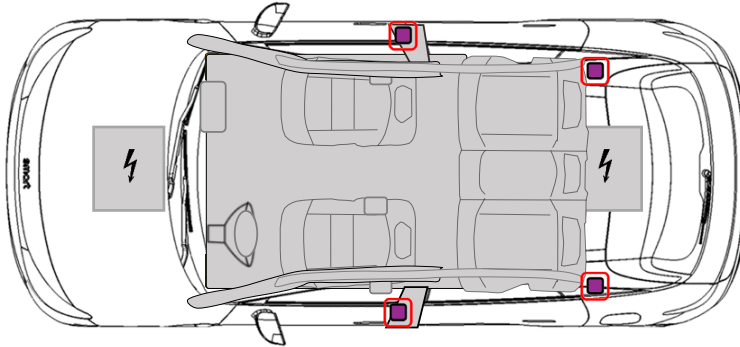

WARNING Electrical and mechanical releases may be compromised after a crash.



Stored gas inflator

The stored gas inflator, outlined in red, are located near the roof and at the top of B-Pillar.

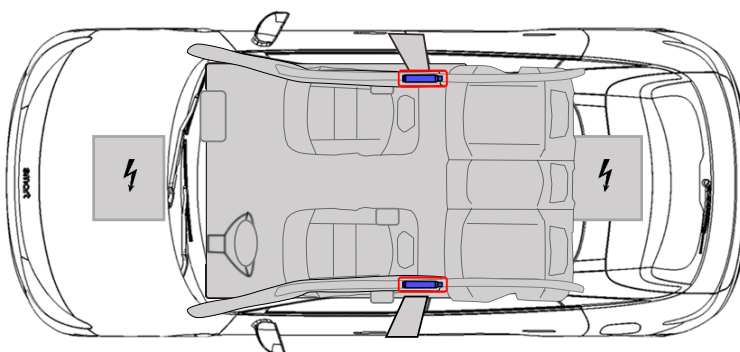

WARNING Rescuers should not cut or crush undeployed stored gas inflator, cutting or compressing them can cause injury or death.



4. Access to the occupants

NOTE: The seats are electrically powered and may not function after a collision.

NOTE: When a vehicle encounters a certain degree of collision accident, the door will automatically unlock and the handle will pop open, which helps passengers escape and personnel rescue. It is also important to remember that every vehicle accident is quiet different and the doors may not unlock automatically from the outside. Extrication may be required.

Opening Doors from the Outside with Power

In an emergency, when the door handle does not pop out:

- (1) push the left corner of the handle to pivot it;
- (2) pull the right side to open the door.

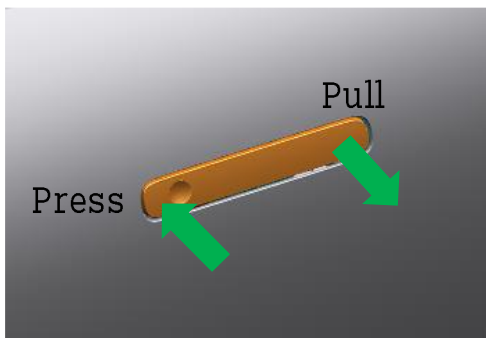

Opening Doors from Inside with/without Power

To open the doors from the inside, manually pull the interior handle of the door to unlock and open the door.

If the rear door cannot be opened after being unlocked, it may be due to child lock locking, requiring opening from the outside of the vehicle or lowering the glass to extend the hand and pull it away from the outside.

When the door cannot be opened, a sharp hard object can be used to knock the corner of the door glass to escape after breaking the window.

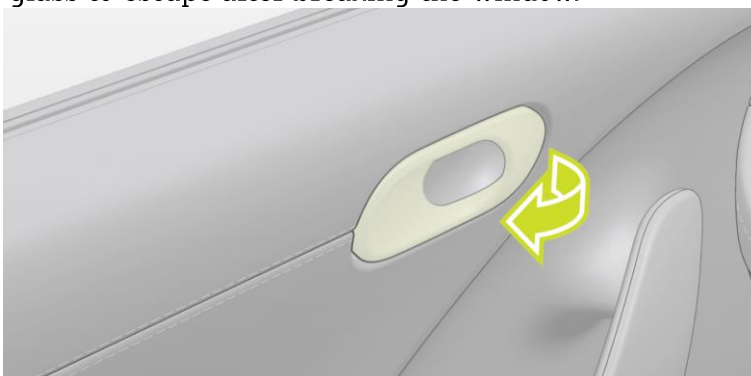



Opening the tailgate with 12V Power

Use one of the following methods to open the liftgate:

- 1, Long press the button on the key fob, see page 5; 
- 2, Long press the button on the driver's side instrument panel switchpack ①.
- 3, Press the button on the tailgate in the middle of badge "a" ②.





Moving the Front Seats with Power

smart #3 has electrically powered seats that can be moved by buttons located on the side of the seat closest to the door. The buttons only work when 12V power is enabled.

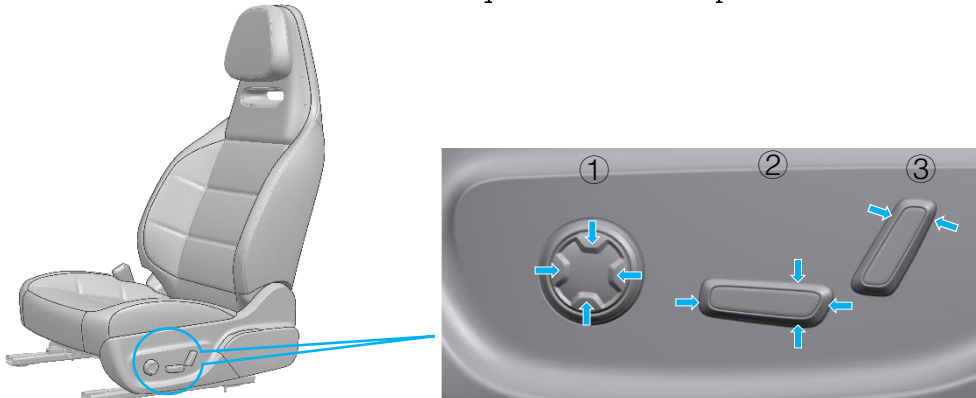

- 1, Adjusts lumbar support.
- 2, Move seat forward/backward and upward/downward.
- 3, Adjusts rest.

NOTE: If 12V power is not available, the front seats cannot be moved.

NOTE: When performing occupant extrication, always check for occupants in the 2nd row seating area.



Opening the Bonnet

smart #3 does not have a traditional internal combustion engine. Therefore, the area that would normally house the engine is used as additional storage space.

Pull the release lever located under the dashboard on the driver's side twice to open the Bonnet.

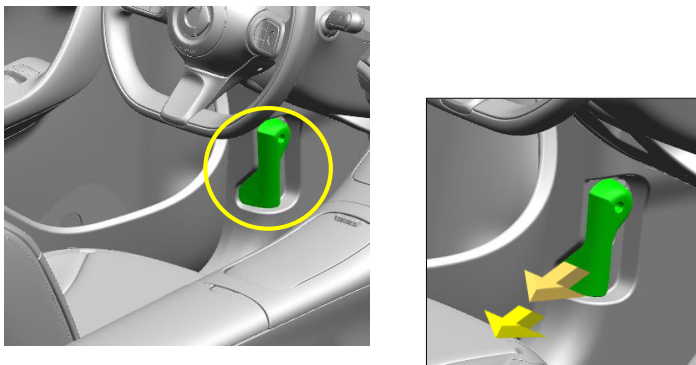

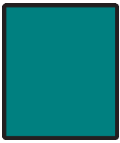

High Strength Zone

smart #3 is reinforced to protect occupants in a collision. Suitable tools must be used to cut these areas. Reinforcements are shown below.

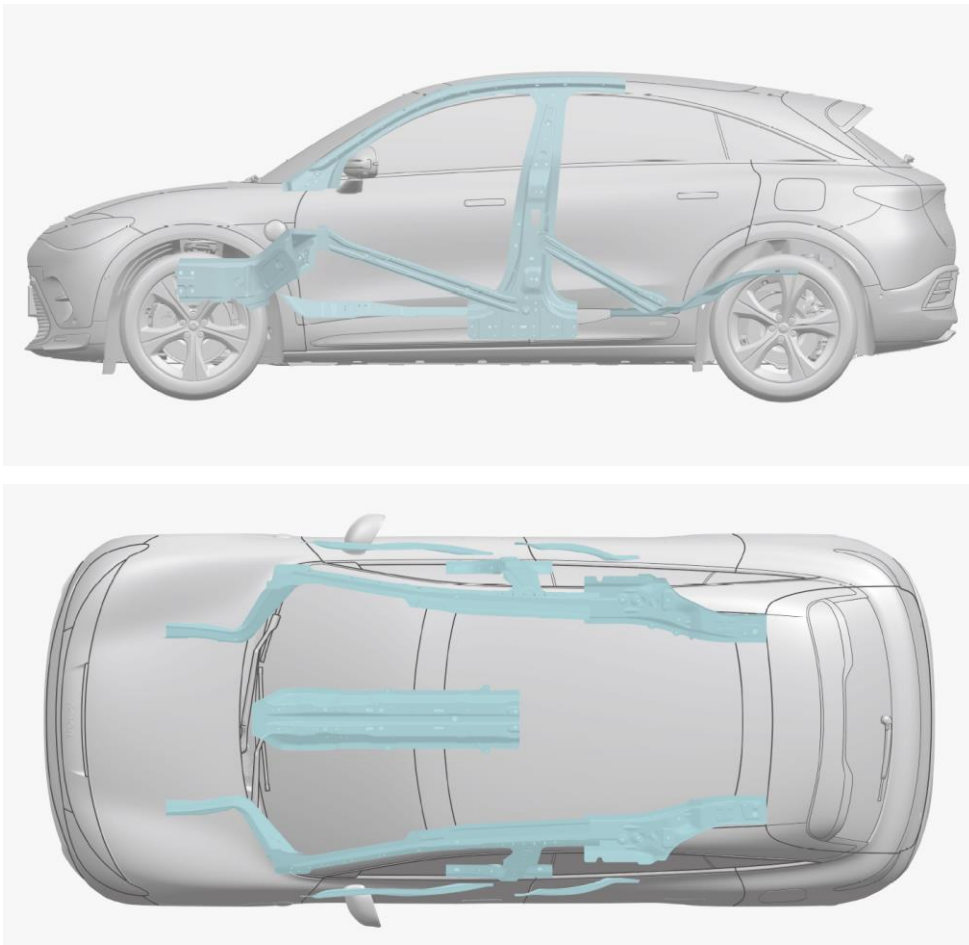

WARNING Do not arbitrarily cut vehicle components. When cutting a vehicle, it is important that professional rescue personnel wear the appropriate PPE and use suitable tools such as hydraulic scissors to cut. Failure to follow these instructions may result in death or serious injury.



WARNING ALWAYS ASSUME THAT ALL HIGH VOLTAGE COMPONENTS ARE ENERGIZED! Cutting, compressing, or touching high voltage components can result in serious injury or death.



No-Cut Zone

#3 has areas that are defined as “no-cut zones” due to the presence of high voltage, gas struts, SRS components, or other hazards. Never cut or crush in these areas. Doing so could result in serious injury or death. The “no-cut zones” are shown in light yellow with red frame.

NOTE: The following image shows a Dual Motor vehicle. Vehicles without a front drive motor are similar.

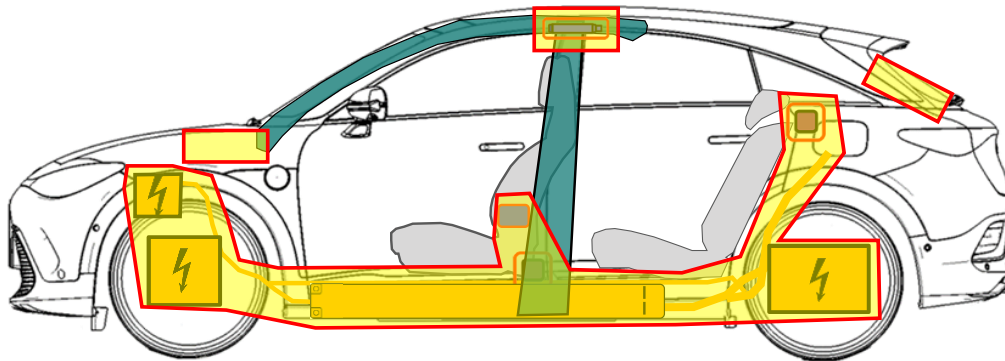

Windows



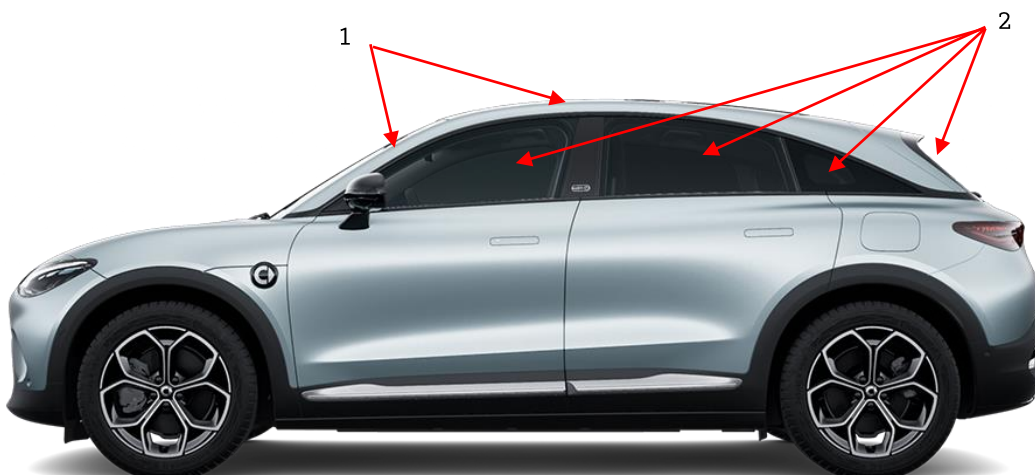



The windshield and roof glass on #3 are made of laminated safety glass. The side windows and tailgate glass are tempered glass.



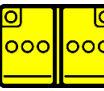

Glass types:

1. Laminated glass.
2. Tempered glass.

5. Stored energy / liquids / gases / solids

		392V		
		12V		
			w/o heat pump	with heat pump
		R-1234yf	500g±20g	950g±20g

 If coolant escapes from the battery cooling system, there is a risk of a thermal reaction in the high-voltage battery. Monitor the temperature of the high-voltage battery! 

 **WARNING** Always wear appropriate PPE.



High voltage component

NOTE: The following images show a Dual Motor vehicle. Vehicles without a front motor are similar.

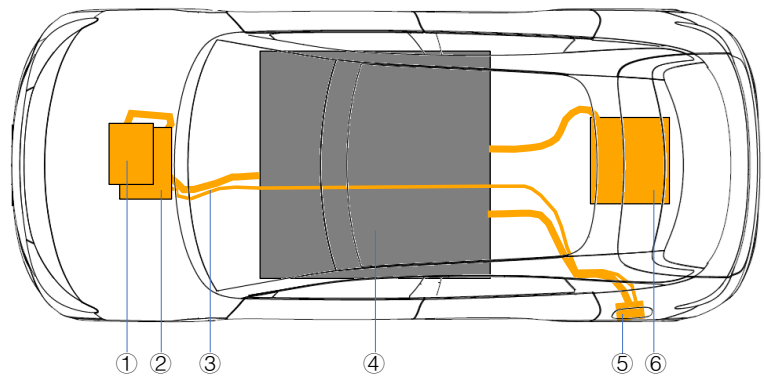

- ① Charger and DCDC module
- ② Front Motor (Dual Motor vehicles only)
- ③ High-Voltage Cable
- ④ High-voltage package
- ⑤ Charge port
- ⑥ Rear Motor



5. Stored energy / liquids / gases / solids



High voltage battery pack

#3 is equipped with a 392V lithium-ion high voltage battery which is mounted to the floor. The battery is made up of several modules that are liquid cooled with color pink coolant. The coolant may leak from the battery pack if the pack has been severely crashed during a vehicle collision. The battery will have stored energy within them. Never breach the high voltage battery when lifting from under the vehicle. When using rescue tools, pay special attention to ensure that you do not breach the floor pan. Refer to Chapter 2: Lift Areas for instructions on how to properly lift the vehicle.

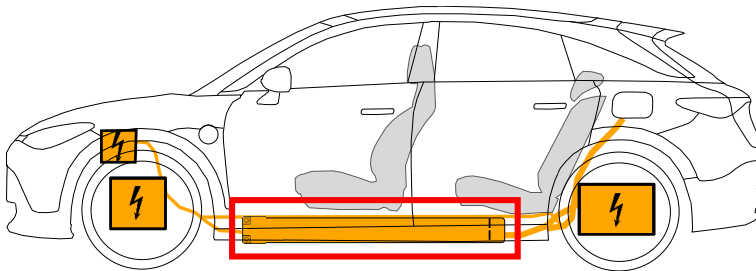

High voltage cables

High voltage cables are shown in orange. There are high voltage cables that run the length of the battery pack between the floor and the battery pack. Do not compromise these high voltage cables with rescue tools. Always assume that there may be high voltage present in the Orange High Voltage Cables.

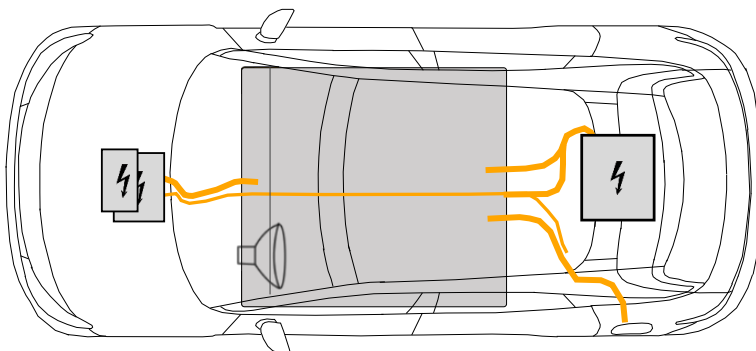



5. Stored energy / liquids / gases / solids

Driver units

The rear drive unit is located between the rear wheels, and the front drive unit (if equipped - for Dual Motor vehicles only) is located between the front wheels.

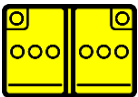
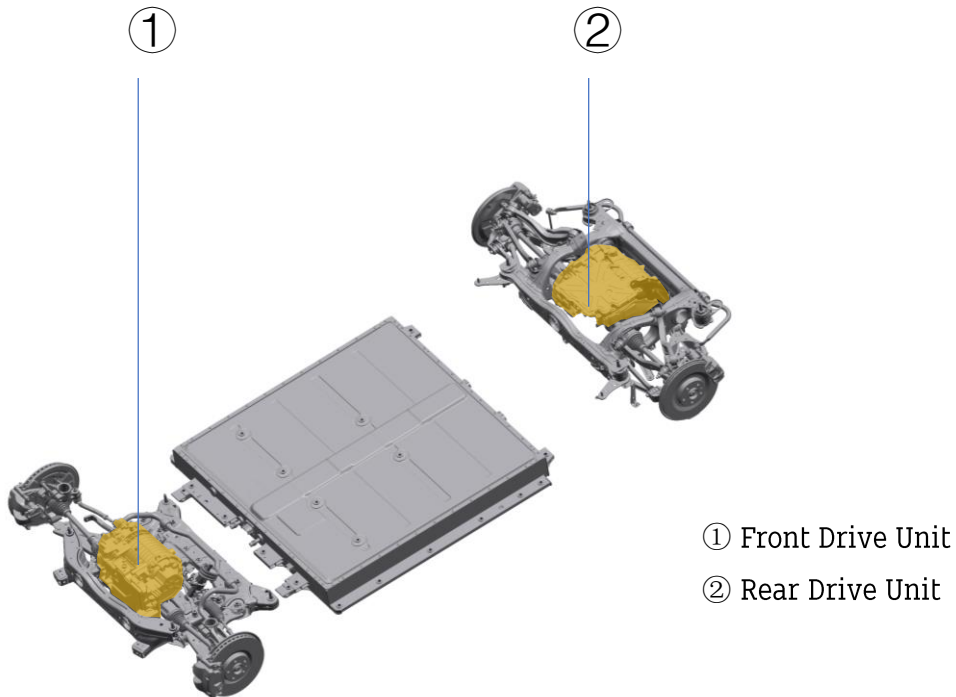

Battery low voltage

In addition to the high voltage system, #3 has a low voltage electrical system. The 12V battery, outlined in red, is located under the hood and 12V battery cover board.

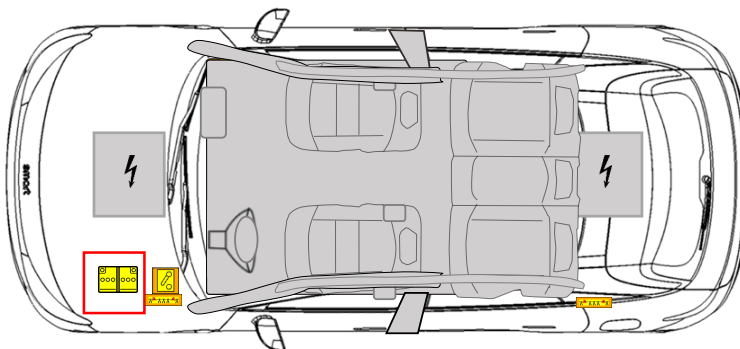



6. In case of fire



USE LARGE AMOUNTS OF PURE WATER



**POTENTIAL RISK OF BATTERY RE-IGNITION /
DELAYED IGNITION!**



Possible risk when the vehicle is on fire.

When the vehicle is on fire, it may be powered on! Do not touch any part of the vehicle without wearing PPE correctly.

High voltage components may be energized when the vehicle is on fire! Cutting, crushing, or contacting high-pressure components can cause death or serious injury. Do not touch any part of the vehicle.

When carrying out rescue work, if there are still passengers in the vehicle, please help them escape first. You can pull the door handle to try to open the door when wearing PPE correctly.

When the door cannot be opened, a sharp hard object can be used to tap the corners of the door glass to help passengers escape by breaking the window.

If smoke is found from the power battery, it should be considered that the power battery is warming up. Please use a high-pressure water gun to cool and extinguish the fire at a distance while wearing PPE correctly, such as helmets, masks, respirators, fire suits, gloves, insulating boots, etc.

After the flame and smoke have significantly weakened, a thermal imaging camera can be used to actively measure the temperature of the power battery and detect heating or cooling trends. It is important to confirm that there will be no re-ignition before moving the vehicle.

After extinguishing the fire, it must be confirmed that the power battery has been thoroughly cooled to prevent it from igniting again.

Before the vehicle leaves the accident site, the power battery must be completely cooled. Be sure to inform the transportation personnel that there is a risk of the power battery re-igniting.



7. In case of submersion

Treat a submerged #3 like any other submerged cars. The #3 doesn't show a greater risk of shock when in water. However, handle any submerged vehicle while wearing the appropriate PPE for water rescue. Remove the vehicle from the water and continue with normal high-voltage deactivation.

Due to the potential risk of high-voltage battery fire, vehicles which have been submerged in water should be handled more carefully. First responders should be prepared to deal with potential fire risks. Raise the front or end of the vehicle to allow water to drain from the vehicle and high-voltage battery pack. After removing the vehicle from the water, continue with the normal disabling process shown in Chapter 3.





8. Towing / transportation / storage



WARNING Never transport the vehicle with the tires in a position where they can spin. Doing so can lead to significant damage and overheating. In rare cases extreme overheating may cause the surrounding components to ignite.

When the wheels rotate, the front or rear drive motors generate power. Always transport with all four tires off of the ground. smart recommends using a flat trailer to tow the vehicle. When towing, the four wheels must be off the ground, otherwise the motor may be seriously damaged.

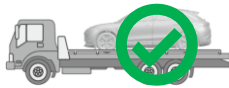

STORE VEHICLE IN AN OPEN-AIR PARKING AT SAFE DISTANCE \geq 5M FROM OTHER OBJECTS OR VEHICLES!



POTENTIAL RISK OF BATTERY RE-IGNITION /DELAYED IGNITION!



Flat trailer or similar transportation vehicles are approved for vehicle transportation.

NOTE: Move the vehicle onto a flat trailer using a winch or move them out of the parking space to position it with the flat trailer. The tires are allowed to rotate and for a very short distance (less than 10 meters) only when Trailer Mode is enable.

Activate the trailer mode

- 1, Ensure the key fob is inside the vehicle,
- 2, Open and close the driver's door once,
- 3, Press and hold the hazard warning lamp switch for more than 7 seconds until the driver information display screen shows it's been self-checked once,
- 4, Switch the gear to neutral N and release the electronic parking brake through the center screen,
- 5, If there is warning information on the center screen or cluster, please clear the information by pressing the button on the right side of the steering wheel.



WARNING In trailer mode, the electronic parking brake does not automatically activate. Please pay attention to the risk of rolling.

If trailer mode cannot be activated or the center screen cannot be accessed, the vehicle can be loaded to an approved transportation location using tow brackets or auxiliary wheels. Before using tow brackets or auxiliary wheels, be sure to check the manufacturer's specifications and recommended load capacity.

smart is not responsible for any damage caused by or during transport of the vehicle, including personal property damage or damage caused by using tow brackets or auxiliary wheels.

Deactivate the trailer mode

Deactivate the trailer mode if any of the following conditions are met.

- 1, Engage the P gear and lock the vehicle from the outside,
- 2, Shift to D or R gear.



9. Important additional information

This document contains important instructions and warnings that must be followed when handling #3 in an emergency situation.



WARNING All the smart #3 vehicles are equipped with a center airbag.



WARNING Always use appropriate rescue tools and always wear appropriate PPE. Failure to follow these instructions can result in serious injury or death.



WARNING Regardless of the disabling procedure you use, ALWAYS ASSUME THAT ALL HIGH VOLTAGE COMPONENTS ARE ENERGIZED! Cutting, crushing, or touching high voltage components can result in serious injury or death.



WARNING After deactivation, the high voltage circuit requires 5 minutes to de-energize.



WARNING Handling a submerged vehicle without appropriate PPE for water rescue can result in serious injury or death.



WARNING When fire is involved, consider the entire vehicle energized. Always wear full PPE.



WARNING When cutting the first responder loop, double cut the loop to remove an entire section. This eliminates the risk of the cut wires accidentally reconnecting.















WARNING When using the high voltage shut down methods recommended by this document, high voltage power is isolated to the battery. The high voltage battery is always energized.



WARNING Never transport #3 with wheels on the ground. Doing so can lead to significant damage and overheating. In rare cases, extreme overheating may cause the surrounding components to ignite.

10. Explanation of pictograms used

	Flammable
	Explosive
	Corrosives
	Hazardous to the human health
	Air-conditioning component
	Electric vehicle
	Cable cut
	Use water to extinguish the fire
	General warning sign
	Acute toxicity
	Use thermal Infrared camera
	Warning, Electricity
	Bonnet